

A EXISTING TYPICAL ROADWAY SECTION DAIRY ASHFORD ROAD
FROM WESTHEIMER TO MEMORIAL
N.T.S.

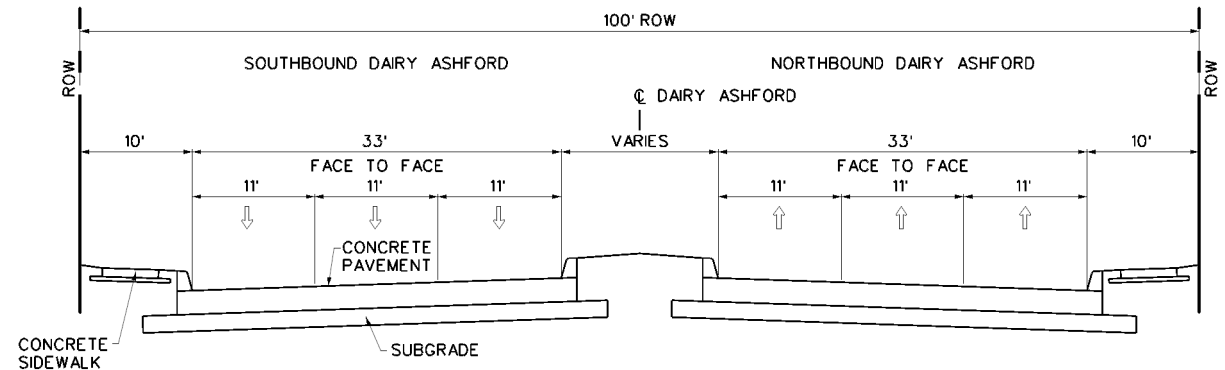

B EXISTING TYPICAL ROADWAY SECTION DAIRY ASHFORD ROAD
FROM WESTHEIMER TO OVERBROOK
FROM MEMORIAL TO I-10
N.T.S.

DATE: \$DATE\$
FILES: \$FILES\$
\$TIMES\$

LEGEND

- EXIST ROW/PARCEL
- SIGNALIZED INTERSECTION

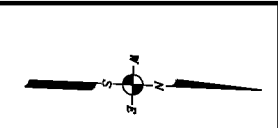

TBPE REG.
NO. F-2742
3131 BRIARPARK
Suite 200
Houston, Texas 77042
Phone (713) 622-1444
Fax (713) 968-9333

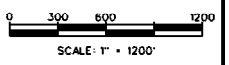

CITY OF HOUSTON
DEPARTMENT OF PUBLIC WORKS AND ENGINEERING

WBS NUMBER	N-0001000-0003-3
CITY OF HOUSTON PM	UMESH KC, P.E.
DATE	07/24/13

**STREET & PAVING IMPROVEMENTS
DAIRY ASHFORD ROAD
WESTHEIMER TO IH-10
OVERALL LAYOUT**